

User Guide

Overview

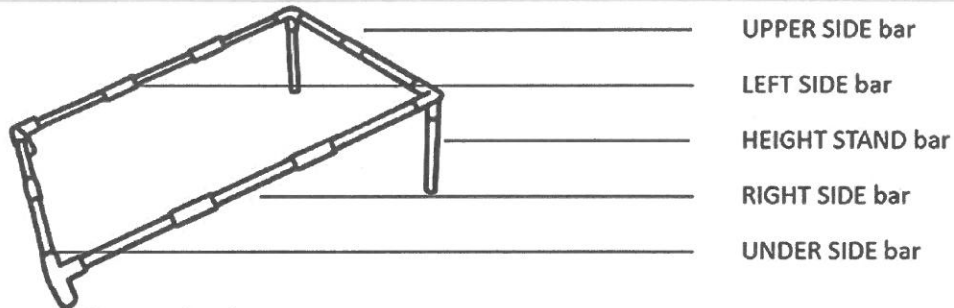

Assembly Method

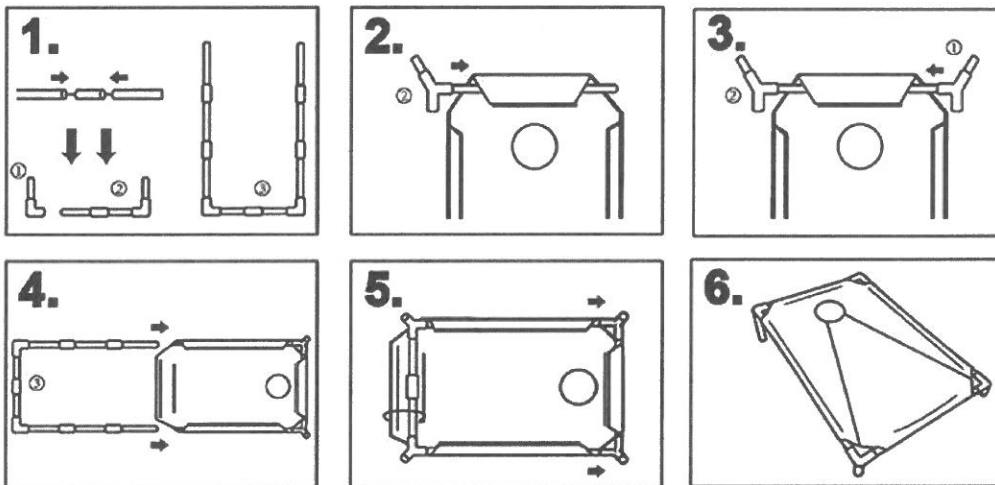

Step 1. Assemble the pipe which has elastic rope, then you will get part1, part2 and part3. (As Pic1 Shown).

Step 2. Put the part2 through the fabric in the upper side, then connect with the part1. (As Pic2, Pic3 Shown)

Step 3. Put the Part3 through the fabric and connect with the part 1 and part2 by tee coupling. (As Pic4 Shown)

Step 4 Stick the Velcro together. (As Pic5 Shown).

-----NOTE: Please make sure the pipe connection hard.-----

Disassembly Method

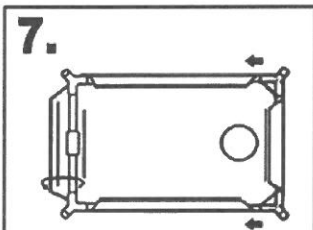

Step 1. Open the bottom magic Velcro, disassemble the part3 along the direction of the arrow (As Pic 6 shown).

Step 2. Disassemble each part in turn, and put them into the storage bag.

NOTE: Please note that the demolition along the direction of the arrow is most convenient.

